

ABSOLYTE[®] GP



SINGLE CELL MODULES SPECIFICATIONS



INDUSTRIAL POWER

A Division of **EXIDE** Technologies

ABSOLYTE[®] GP

THE WORLD LEADER IN VRLA BATTERY POWER

- Environmentally friendly positive grid alloy provides reduced hazardous material content¹ and allows global recycling.
- Patented Lead-Calcium-Tin-Silver positive grid alloy provides long life in both float and cycling applications.
- Absorbed glass mat (AGM) separators provide >99% recombination efficiency.
- Low resistance of the glass mat improves high rate discharge performance.
- Cells are housed in protective, individual steel trays with convenient lifting handles for easy transport to remote locations.
- The single cells may be operated in the horizontal (preferred) or vertical position.²
- No water additions are required.
- Periodic visual inspections, voltage readings and connection retorquing is all that is required.



APPLICATIONS

- Railroad Signal and Communications
- Photovoltaics
- Cellular Radio
- Alternative Energy Systems
- Telecommunications

ADDED FEATURES & BENEFITS

- Does not require separate battery room
- Can be integrated into other equipment enclosures
- Freezing tolerant
- Deep discharge recovery
- Accepts high rate charge
- Globally Recyclable
- Greater use of reprocessed materials compared to prior Absolyte products.

CELL SPECIFICATIONS

Design Life — 20 Years in Float Applications at 25°C (77°F)³

Container and Cover — Polypropylene is standard. Flame retardant, UL94 V-0/28% L.O.I. is optional.

Separators — Spun glass, microporous matrix.

Safety Vent — 3-10 PSI opening pressure, self-resealing.

Terminals — Solid copper insert.

Positive Plate — Patented Lead-Calcium-Tin-Silver grid alloy.

Negative Plate — Lead calcium grid alloy.

Self Discharge — 0.5 to 1% per week maximum @ 25°C (77°F).

Float Voltage — 2.23 to 2.27 VPC (2.25 recommended) @ 25°C (77°F).

Cycle Life — 1200 Cycles to 80% DOD at 25°C (77°F)³

Operating temperature — Temperature excursions between -40°C (-40°F) to +50°C (122°F) allowed (battery performance and life will be affected)

1. Compared to Absolyte IIP

2. 50G single cells only.

3. When operated per I&O Manual

ABSOLYTE[®] GP

Absolyte GP Single Cell Module Weights and Dimensions

CELL TYPE	NOM AH CAP (8 HR)	LENGTH		WIDTH		DEPTH OR HEIGHT		WEIGHT	
		IN	MM	IN	MM	IN	MM	LB	KG
50G									
50G05	104	3.80	97	6.49	165	16.00	406	32	15
50G07	152	3.80	97	6.49	165	16.00	406	39	18
50G11	264	4.55	116	6.49	165	16.00	406	50	23
50G13	312	5.30	135	6.49	165	16.00	406	58	26
50G15	368	6.05	154	6.55	166	16.00	406	66	30
50G19	472	7.67	195	6.67	169	16.00	406	91	41
50G27	680	10.67	271	6.67	169	16.00	406	124	56

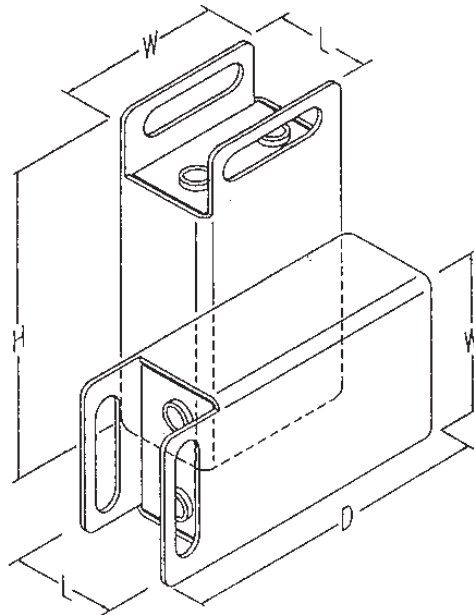

Absolyte GP Performance Specifications Amperes to 1.75 Final Volts PerCell @ 25°C (77°F)

CELL TYPE	HOURS													
	100	72	36	24	20	16	12	10	8	6	4	3	2	1
50G														
50G05	1.4	1.9	3.6	5.1	6.0	7.3	9.3	11	13	16	22	27	37	58
50G07	2.1	2.9	5.5	7.7	9.1	11	14	16	19	24	3	41	56	87
50G11	3.6	4.9	9.1	13	15	18	23	27	33	41	56	69	94	146
50G13	4.3	5.9	11	15	18	22	28	33	39	49	67	83	112	175
50G15	5.1	6.9	12	18	21	25	32	38	46	57	78	97	131	204
50G19	6.5	8.9	16	23	27	33	42	49	59	74	101	125	169	262
50G27	9.5	12	23	33	39	47	60	71	85	107	146	181	244	379

Note: Design and/or specifications subject to change without notice. If questions arise, contact your local GNB sales representative for clarification.
 • Rates shown assume connectors that are properly sized.

Exide Technologies – The Industry Leader.



ABSOLYTE

GNB Flooded Classic

MARATHON

RELAY GEL

Sonnenschein

Sprinter

GNB Industrial Power, a division of Exide Technologies is a global leader in stored electrical energy solutions for all major critical reserve power applications and needs. Network power applications include communication/data networks, UPS systems for computers and control systems, electrical power generation and distribution systems, as well as a wide range of other industrial standby power applications. With a strong manufacturing base in both North America and Europe and a truly global reach (operations in more than 80 countries) in sales and service, GNB Industrial Power is best positioned to satisfy your back up power needs locally as well as all over the world.

Based on over 100 years of technological innovation the Network Power Division leads the industry with the most recognized global brands such as ABSOLYTE®, SONNENSCHWEIN®, MARATHON®, SPRINTER®, RELAY GEL® and GNB FLOODED CLASSIC™. They have come to symbolize quality, reliability, performance and excellence in all the markets served.

Exide Technologies takes pride in its commitment to a better environment. Its Total Battery Management program, an integrated approach to manufacturing, distributing and recycling of lead acid batteries, has been developed to ensure a safe and responsible life cycle for all of its products.

GNB Industrial Power

A Division of Exide Technologies
USA – Tel: 888.898.4GNB (4462)
Canada – Tel: 800.268.2698

www.exide.com

SECTION 26.12 2008-08

GNB®

INDUSTRIAL POWER

A Division of **EXIDE** Technologies